

NUMERICAL ANALYSIS FOR 3D INFLUENCE OF PILE PULLING-OUT HOLES ON SURROUNDING GROUND

Shuichi Kuwahara¹ and Shinya Inazumi²

¹Marushin Co. Ltd., Japan

²Shibaura Institute of Technology, Japan

ABSTRACT

The demolition of social infrastructures including the civil structures have been increasing because of aging them constructed during in a period of high economic growth and decrease in their utilization with a population decrease, in recent years. As a result, removal works of existing pile in the ground have been increasing. Pulling-out method is adopted for removal of existing a pile foundation in the present circumstances. However, after pulling-out a pipe foundation, decline of mechanical characteristic of surrounding ground is concerned by forming pulling-out holes. There are no regulations yet for filler injected into a pulling hole, and the influence of the strength of the filler on surrounding ground is not considered. This study considers the influence by which a pulling-out hole of a pipe foundation gives it to static characteristics of surrounding ground by using 3D elastic-plastic finite element analysis. The special qualities required for fillers injected into a pulling-out hole are also clarified in this study.

Keywords: Finite element method, Pile foundation, Pulling-out method, Pulling-out hole,

INTRODUCTION

In Japan, many of the city located in the soft ground, there are many structures using a pile foundation. Therefore, to achieve a new land utilization at the place where existed structures are present, it is necessary to remove existed pile supported the structure as well as existed structures for construction of a new structure. Further, existed piles and concrete husk become industrial waste, be left of these industrial waste in the ground is a very difficult problem. In addition, it is seen troubles many as "hidden defect" in the sale of land transactions [1]. Accordingly, it can be said that the removal of existed pile is essential.

The removal method of existed pile, there is a pulling-out method and crushing removal method, and the like. But the crushing removal method are having such as vibration, noise and environmental problems. The pull-out method has been widely used from this thing. However, there are also problems in the pull-out method. The pulling-out hole is formed when pulling out the existed pile. If the pulling-out hole is left, the collapse of the empty drilling part of the earth and sand, and there is a possibility that the subsidence of the ground surface by the gap widening in the ground occurs. Therefore, it is necessary to fill the pulling-out hole by injection of the fillers. About fillers, conventionally, in many cases to construction in mountain sand and recycled sand from construction it is easy and inexpensive. But, by cannot ensure a reliable filling and stable strength, in recent years the flow of processing soil

and cement-bentonite use has increased. However, there are no regulations yet on fillers injected into a pulling-out hole, and the influence by which the strength of the fillers gives it to the surrounding grounds is not also elucidated.

This study considers the influence by which a pulling-out hole of a pile foundation gives it to static characteristics of surrounding grounds by using three-dimensional static finite element analysis. The special qualities required for fillers injected into a pulling-out hole are also clarified in this study.

STUDY SUMMARY ABOUT THE STATIC BEHAVIOR OF THE PULLING-OUT HOLE AND THE ORIGINAL GROUND

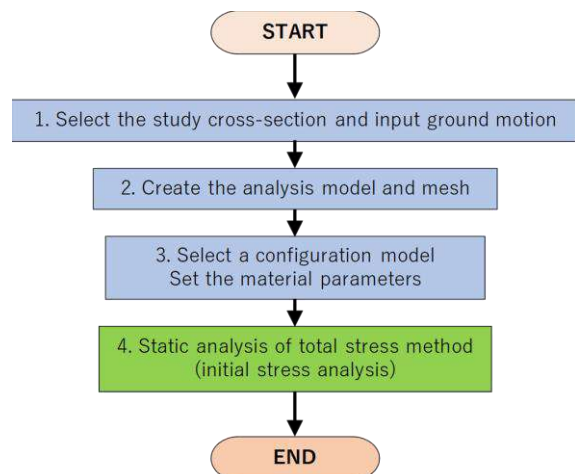
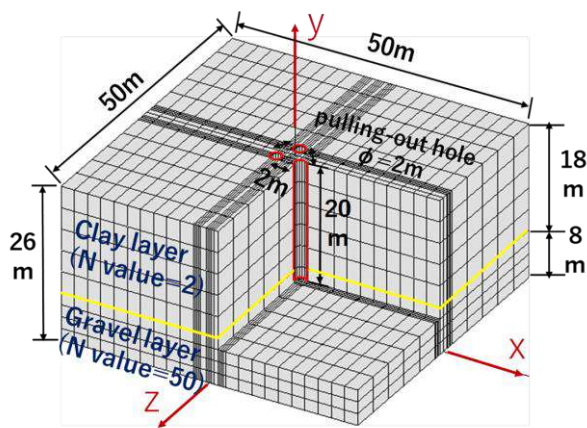
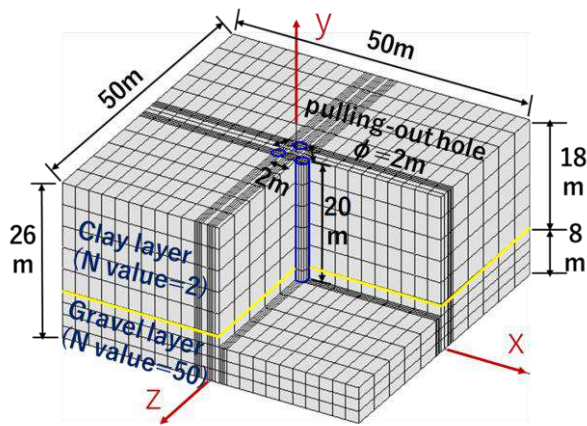

Fig. 1 Analysis procedure



(a) When the pulling-out holes are hollow



(b) When the pulling-out holes are injected the filler

Fig. 2 Sectional view and Analysis model

Describe the content of this study with (1) to (4) (see Fig. 1).

- (1) To select the study cross-section.
- (2) To create the analysis model, based on the selected cross-section in the 1. And the analysis area to mesh division.
- (3) To select an analysis constant. To set the application configuration model and material parameters in the initial stress analysis.
- (4) Perform the initial stress analysis. Analysis technique is a total stress analysis. In this study, elastic-plastic model for the ground material and hollow portion has been applied.

THE STATIC BEHAVIOR OF THE PULLING-OUT HOLE AND THE ORIGINAL GROUND, ANALYSIS MODEL

Analysis Model

Table 1 Element parameters

Material name	Clay layer	Gravel layer	filler
γ_t (kN/m ³)	14	19	15
Constitutive law	Elastic-plastic model		

Table 2 Ground parameters

Material name	Clay layer	Gravel layer
E (kN/m ²)	7900	140000
ν (-)	0.45	0.35
S_u (kN/m ³)	37.8	152.9
ϕ (°)	0	42.3

Table 3 Filler parameters

Filler	q_u (N/mm ²)	E (kN/m ²)	ν (-)	S_u (kN/m ³)	ϕ (°)
1	0.1	1.36×10^5	0.48	38.3	26.0
2	0.5	5.88×10^5	0.48	182.3	39.5
3	1.0	11.5×10^5	0.48	362.2	49.6

In the analysis, the analysis cross-section has a two-layer, upper layer part is clay layer as soft strata, which N value is about 2. And under layer part is gravel layer as strong formations serving as a support layer, which N value is about 50. The front and side width of the analysis cross section is set to 50m, the thickness of the clay layer is 18m, the thickness of the gravel layer is 8m, and the total depth of the cross section is 26m. About pulling-out holes, the number is three, pore diameter is 2m, depth is 20m, and embedment depth into the gravel layer is the 2m. For mesh division, improve the accuracy of analysis by finer mesh spacing near the pulling-out hole. Also, even when filled with pulling-out holes, it is finer mesh in order to examine the behavior of the filling portion of the pulling-out hole. As a boundary condition, the bottom is fixed fulcrum, and the lateral boundary is fixed in the vertical direction.

In the analysis, filler material is fluidization treated soil [2], [3]. The analysis cross-sectional view of the ground, analysis model and axial direction are shown in Fig. 2. In the figure, the portion surrounded by red frame is hollow portion and blue frame is filler portion. And a yellow line indicates a boundary between clay layer and gravel

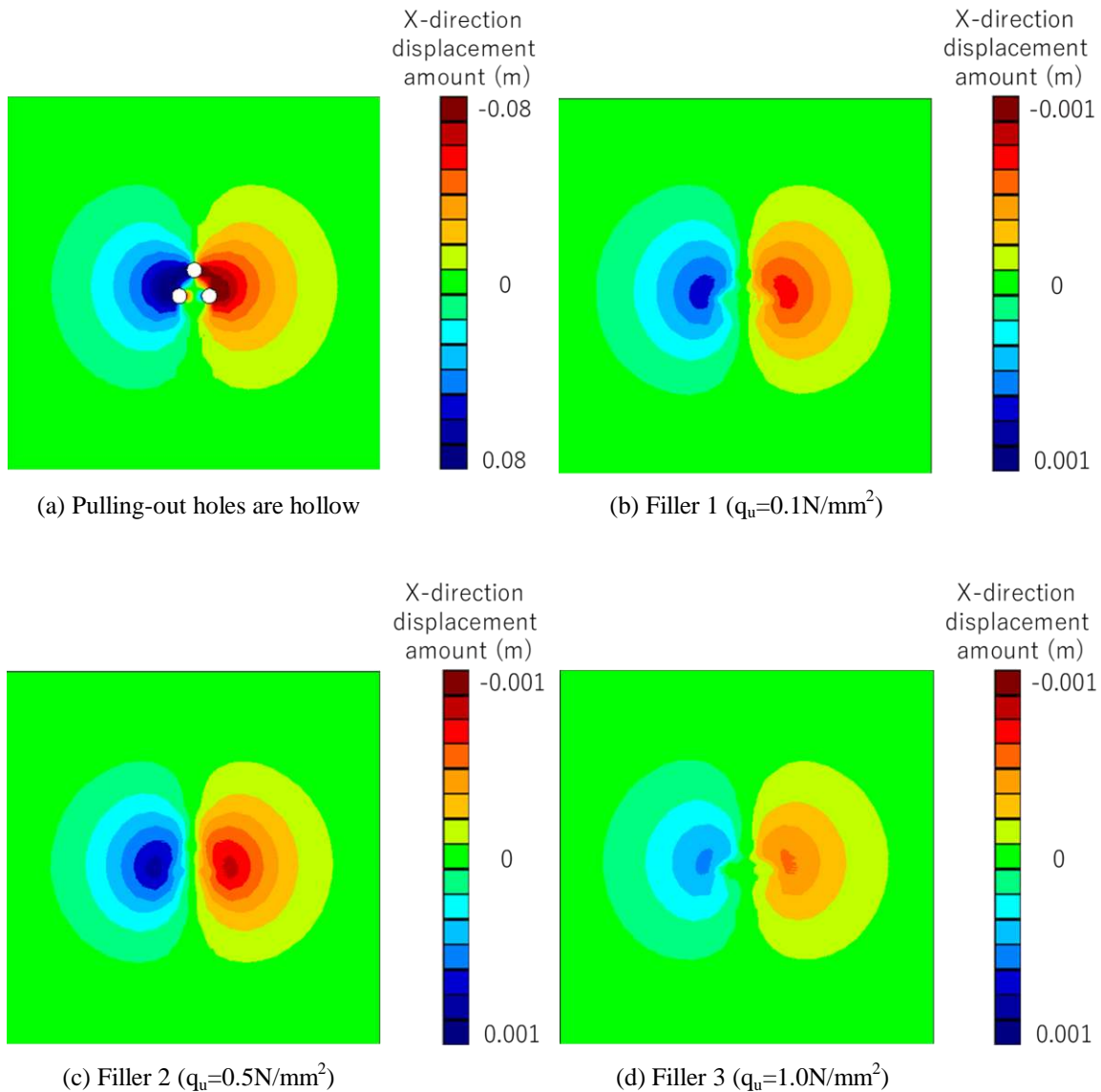

Fig. 3 X-direction displacement amount contour figure at ground surface

layer.

Constitutive Law and Material Parameters

Parameters in the clay layer and gravel layer used for the analysis and soil parameters in the pulling-out hole are shown in Tables 1 and 2. In this analysis, using a fluidizing processing soil that many of the experimental value. In addition, it analyzes in three fillers with different elastic modulus of the fluidizing process soil in order to examine the effect of filler strength has on the ground. From having a small strength, the filler 1, filler 2, filler 3. Parameters used in the analysis is to determine the anamnestic literature reference (see Table 3).

γ_t represents unit volume weight of the soil. E represents elastic coefficient. ν represents Poisson's

ratio. S_u represents shear strength. ϕ represents internal friction angle. q_u represents compressive strength.

ANALYSIS RESULTS AND STUDY ON THE DYNAMIC BEHAVIOR OF THE PULLING-OUT HOLE AND THE ORIGINAL GROUND

In this study, to compare the ground when injecting three types of filler on the ground when the pulling-out holes are hollow, in the static analysis. The results are shown in the following.

Results of the Analysis

Figures 3, 4 and 5 show the results about the

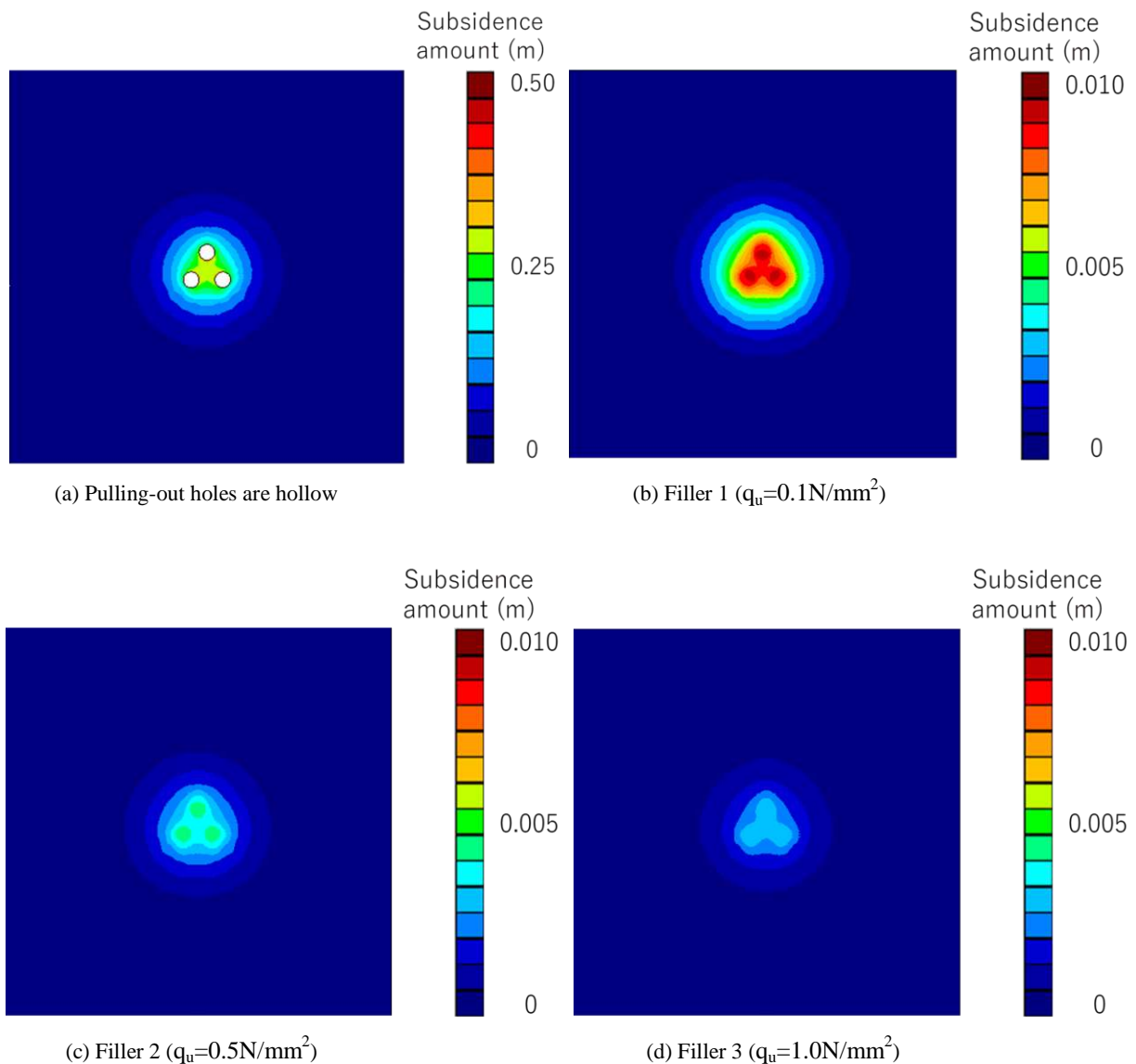

Fig. 4 Settlement amount contour figure at ground surface

effect of the pulling-out holes in the hollow and 3 types of fillers with different strength on the surrounding ground by this study. Figure 4 is the contour figure showing x-direction displacement amount on the ground surface when the pulling-out holes are hollow and when each filler with different strength is fixed. Figure 5 is the contour figure showing settlement amount on the ground surface in the same case as above. Figure 6 is the graph comparing settlement amount on the ground surface in the same case as above. These are premises that the filler is injected uniformly [4].

Study on the Results of the Analysis

From Fig. 3, the maximum x-direction displacement amount is 0.080m when the pulling-

out holes are hollow. In that case, it shows that surrounding ground is deforming to block the pulling-out holes. And the maximum x-direction displacement amount is 0.001m when the pulling-out holes are fixed with filler.

In that case, it shows that surrounding ground on the ground surface is deforming toward the center of the ground surface. It is because of the filler is resistant to deformation due to the filler is injected. So that, it can be said that x-direction displacement is reduced by injecting the filler into the pulling-out holes. And, x-direction displacement reduces as the strength of the filler.

From Figs. 4 and 5 the maximum settlement amount is about 0.30m in the part sandwiched by the pulling-out holes when the pulling-out holes are hollow. It is because that the stress concentrates

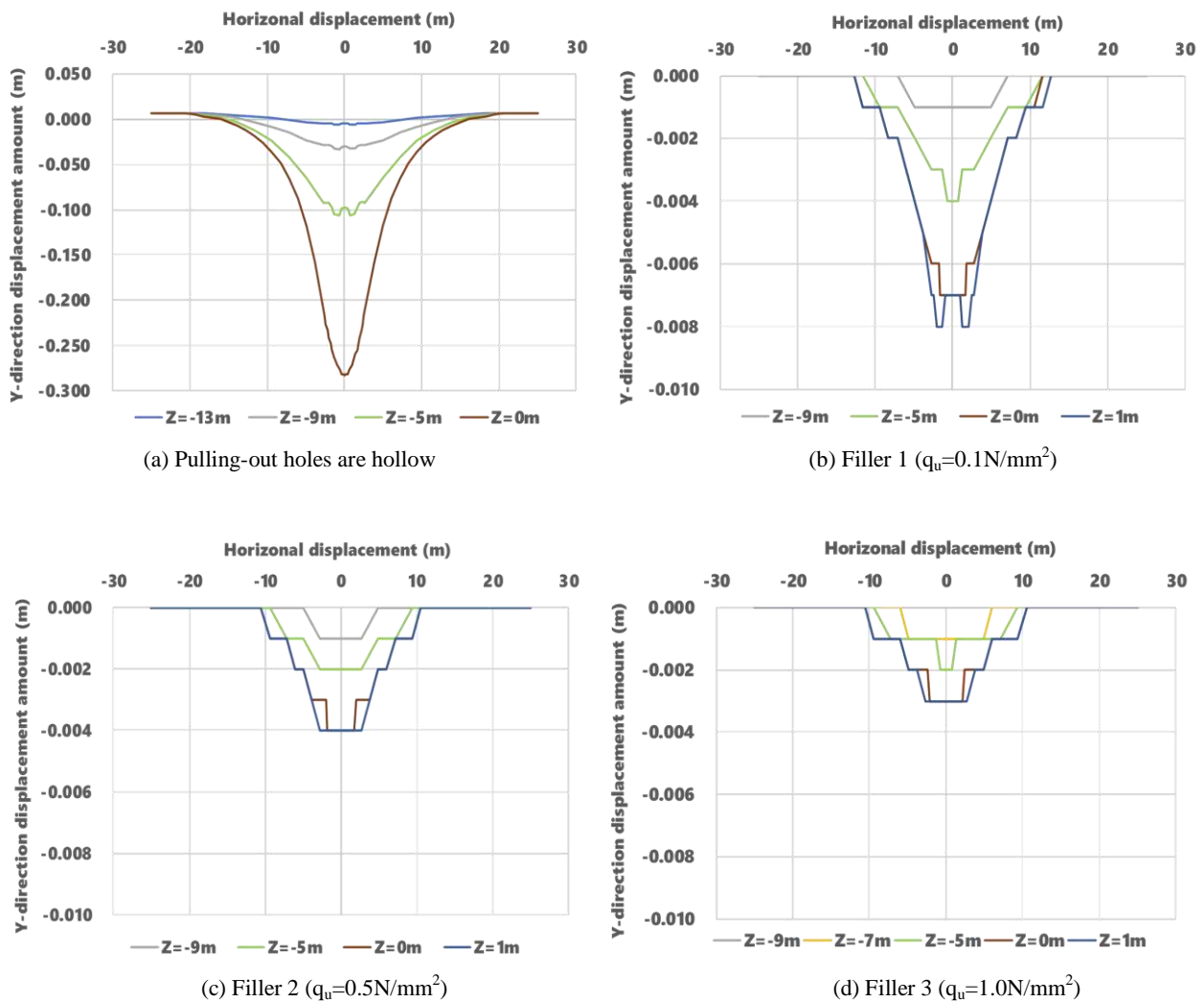

Fig. 5 Settlement amount graph at ground surface

around the pulling-out holes by excavation. The area of influence of settlement in x-direction is -15m to 15m and the ground surface rise in the outside that area. As downward stress acts by initial stress analysis, downward stress is released by excavation and upward stress acts, so it can be said to rise away from the area of influence of settlement. As above, it can be said that ground improvement is necessary because the settlement amount is large.

And the maximum settlement amount is 0.008m when the pulling-out holes are fixed with filler 1 ($q_u=0.1N/mm^2$). The area of influence of settlement in x-direction is -11m to 11m. And the maximum settlement amount is 0.004m with filler 2 ($q_u=0.5N/mm^2$). The area of influence of settlement in x-direction is -9.5m to 9.5m. And the maximum settlement amount is 0.003m with filler 3 ($q_u=1.0N/mm^2$). The area of influence of settlement in x-direction is -9.5m to 9.5m. In the case of injecting filler 1, 2 and 3, no settlement occurs

outside that area. When filler is injected, settlement amount is less than 0.008m, and settlement amount is greatly reduced as compared with when pulling-out holes are hollow. It is because that stress concentration on pulling-out holes can be prevented by injecting the filler. Therefore, it can be said that by filling the pulling-out holes, the settlement of ground is suppressed. And the area becomes smaller as the strength of the filler increases.

From Fig. 4, injecting filler 1 ($q_u=0.1N/mm^2$), the settlement amount is locally large in the filler part. It is because that the compressive stress acts greatly from the surrounding ground on the filler part due to the small filler strength. Comparing filler 2 ($q_u=0.5N/mm^2$) and filler 3 ($q_u=1.0N/mm^2$), the settlement amount has only 0.001m difference, and there is almost no difference in the area of influence of settlement.

The filler of strength $0.5N/mm^2$ is defined as the same strength as the ground, which is prescribed in

the “Public building construction standard specification (Building work) [5]”, so it is adopted as standard compound, in recent years. Besides it there is no reason.

However, from the above, in this study’s analysis section, it is desirable to inject the filler of strength 0.5N/mm^2 to the pulling-out holes of existing piles in consideration of economics.

CONCLUSIONS

In this study, the influence of the pulling-out holes on surrounding ground was evaluated by three-dimensional static FEM analysis for development of pulling-out of existing piles.

When the pulling-out holes are hollow, the maximum settlement amount is about 0.30m in the part sandwiched by the pulling-out holes. But, when the pulling-out holes are fixed with filler that strength over 0.1N/mm^2 , the settlement amount is less than or equal to 8mm. And the area of influence of settlement becomes smaller when the filler injects into the pulling-out holes than when the pulling-out holes are hollow. Therefore, it becomes clear that injecting the filler is an effective means to suppress ground settlement.

In this study’s analysis section, the settlement amount is locally large in the filler part when the filler 1 ($q_u=0.1\text{N/mm}^2$) injects. And, it is possible to prevent local settlement when the filler 2 ($q_u=0.5\text{N/mm}^2$) and 3 ($q_u=1.0\text{N/mm}^2$) inject. Comparing filler 2 ($q_u=0.5\text{N/mm}^2$) and filler 3 ($q_u=1.0\text{N/mm}^2$), the settlement amount has almost no difference, and there is almost no difference in

the area of influence of settlement. Therefore, it is desirable to inject the filler of strength 0.5N/mm^2 to the pulling-out holes of existing piles in consideration of economics.

As this study’s future work is that it is necessary to examine the influence of this analysis compared with this analysis result when changing ground parameters, arrangement number of the pulling-out holes, compounding materials for filler. And, identify the strength of filler generally required.

REFERENCES

- [1] Takao M., Leaving the foundation pile, backfilling denied the defects of ground support force of the part, agent of accountability violation was also negative case, RETIO, No.82, pp.166-167, 2011.
- [2] Yasushi F., Futa N., Yasushi U., Keisuke T., Study on the Young's modulus of the fluidized processing soil. Summaries of technical papers of annual meeting Architectural Institute of Japan, pp.591-592, 2014.
- [3] Yasushi F., Deformation properties of the backfill material which has a fluidity and self-hardening, Town Value-up Management report, No.37, pp.41-44, 2011.
- [4] Marushin Co., Ltd., About the pulling out method of the existing pile, Retrieved April 21, 2018, from <http://marushinn.jp/handbook/>
- [5] Ministry of Land, Infrastructure, Transport and Tourism, Public Building Construction Standard Specification (Building Work) 2013 Edition, MLIT, 2016.